

REPAIR PARTS LIST

LISTE DE PIÈCES DE RECHANGE

LISTA DE PIEZAS DE REPARACIONES

WS SERIES/SÉRIE/SERIE

Submersible Sewage & Effluent Pumps
 Pompes De Puisard/effluents Submersibles
 Bombas Sumergibles De Desagüe Y Efluentes
 (WS30, WS31, WS41, WS51, WS52)



Water Systems
 Systèmes d'eau
 Sistemas De Agua

Sump and Sewage
 Puisards et égouts
 Sumideros & Desagües

Lawn and Sprinkler
 Pompes d'arrosage
 pour pelouse et jardin
 Bombas Por Aspersión
 Para Riego De Jardines

Electric Motor Driven
 Pompes à moteur
 électrique
 Impulsadas Por Motor
 Eléctrico

Engine Driven
 Pompes à moteur à
 essence
 Impulsadas Por Motor

Frame Mount
 Montées sur châssis
 Para Acople

Hand Pumps
 Pompes manuelles
 Bomba Manuales

Irrigation and Industrial
 Pompes d'irrigation et
 pompes industrielles
 Bombas Para Irrigación
 & Industrials

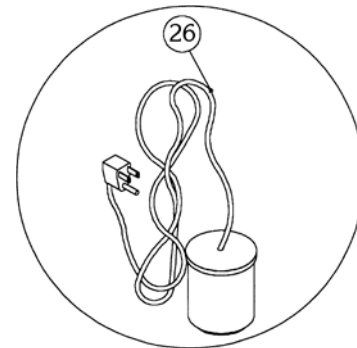
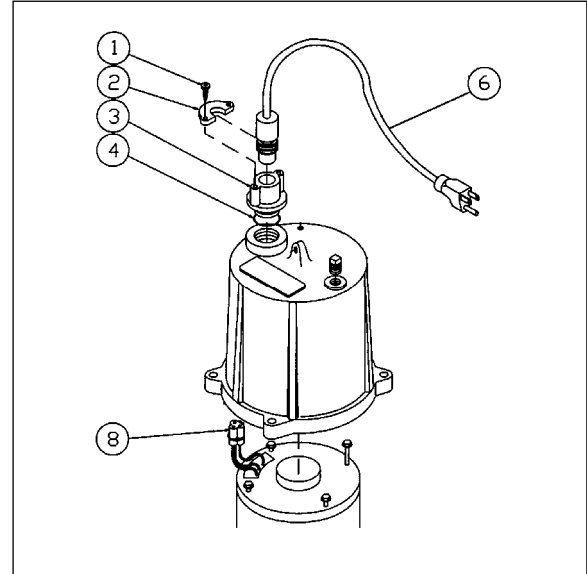
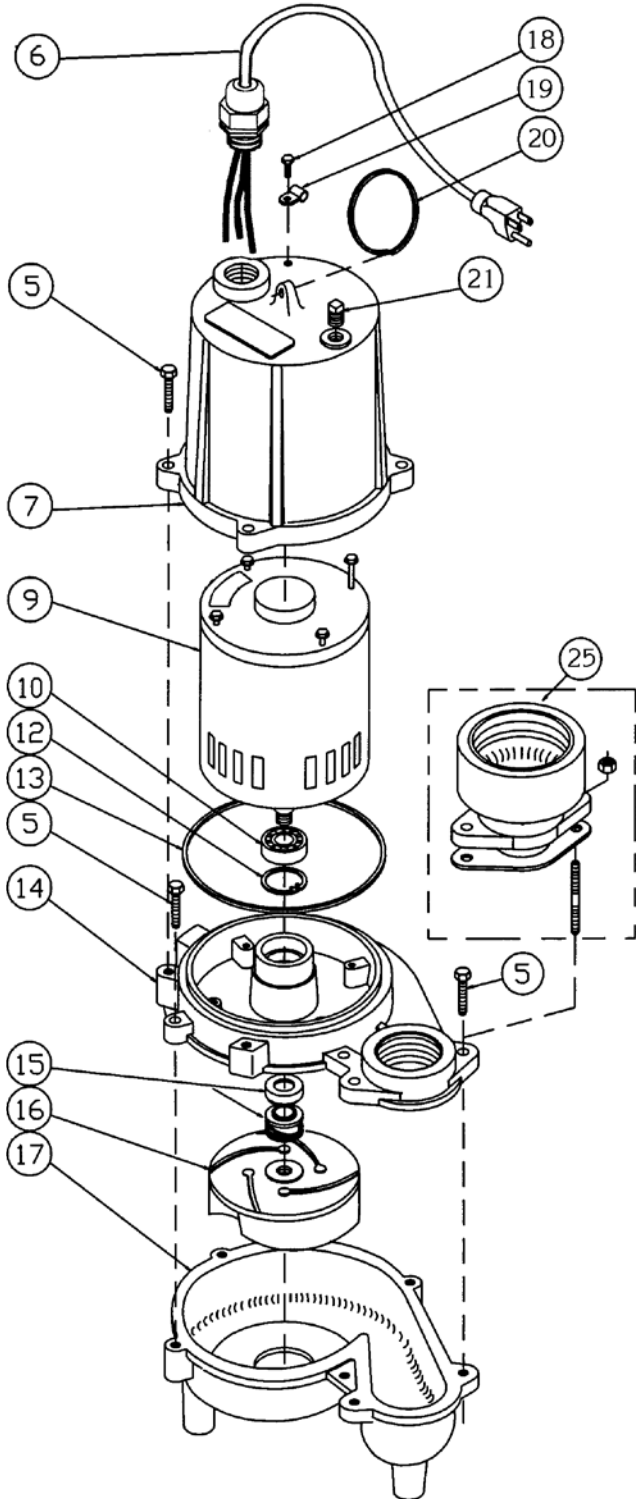

Uses 2.1 liters of Dielectric Oil. Available in 1 liter containers.

Nécessite 2,1 litres d'huile diélectrique disponible en contenant de 1 litre.

Usa 2.1 litros de aceite Dielotric. Disponible en envases de 1 litro.

200125R8 0506

COL.	MODELS ENDING IN: MODÈLES SE TERMINANT PAR; MODELOS QUE SE TERMINAN CON:	TYPE CURRENT TYPE COURANT TIPO CORRIENTE	Suffix "AM" designates automatic. Suffix "M" designates manual. Suffixe "AM" désigne automatique. Suffixe "M" désigne manuel. Sufijo "AM" designa automático. Sufijo "M" designa manual.
a	30AM, 30M, 31EA, 31EM	(type C)	
b	41AM, 41M, 41SA, 41SM	(type B)	
c	51AM, 51M, 51SA, 51SM	(type B)	
d	52AM, 52M, 52SA, 52SM	(type B)	
e	30AM, 30M, 31EA, 31EM	(type E)	
f	41AM, 41M	(type D)	
g	51AM, 51M	(type D)	
h	52AM, 52M	(type D)	

Ref. #	Code #	a	b	c	d	e	f	g	h	Description	Description	Descripción	
1**	149413	2	2	2	2					Screw #10 x 3/4 SST	Vis #10 x 3/4 SST	Tornillo #10 x 3/4 SST	
2**	246331	1	1	1	1					Clamp	Collier de serrage	Abrazadera	
3**	246330	1	1	1	1					Adapter	Adaptateur	Adaptador	
4	198080	1	1	1	1					O-ring 1 3/8 I.D.	Joint torique 1 3/8 I.D.	Anillo "O" 1 3/8 I.D.	
5	225820	10	10	10	10	10	10	10	10	Bolt 5/16" UNC x 1-1/4" SST	Boulon 5/16 UNC x 1-1/4 SST	Perno 5/16 pulg. UNC x 1-1/4 pulg. SST	
6	225076					1	1	1	1	Cord 20 ft.	Cordon, 20 pi	Cable, 20 pies	
6**	255051	1	1	1	1					Cable, 20 ft.	Cordon, 20 pi	Cable, 20 pies	
7	493541	1	1	1	1	1	1	1	1	Housing	Boîtier	Cuerpo de la bomba	
8**	225055	1	1	1	1					Plug assembly	Prise du courant	Conector	
9	223150	1								Motor 1/3 HP	Moteur 1/3 CV	Motor 1/3 HP	
9	223151		1	1	1					Motor 1/2 HP	Moteur 1/2 CV	Motor 1/2 HP	
9	223160					1				Motor 1/3 HP	Moteur 1/3 CV	Motor 1/3 HP	
9	223161						1	1	1	Motor 1/2 HP	Moteur 1/2 CV	Motor 1/2 HP	
10	110110	2	2	2	2	2	2	2	2	Bearing	Coussinet	Rodamiento	
11	620581	2.1	2.1	2.1	2.1	2.1	2.1	2.1	2.1	Insulating Oil	Huile isolante	Aceite aislante	
12	137911	1	1	1	1	1	1	1	1	Retaining Ring	Bague de retenue	Anillo de retención	
13	198994	1	1	1	1	1	1	1	1	O-Ring, Square	Joint torique, carré	Sello de hule, cuadrado	
14	493552	1	1	1	1					Adapter	Adaptateur	Adaptador	
14	493563					1	1	1	1	Adapter	Adaptateur	Adaptador	
15	240160	1	1	1	1	1	1	1	1	Mechanical Seal, 5/8" I.D.	Joint mécanique, 5/8, D.I.	Sello mecánico, 5/8 pulg. I.D.	
16	493223	1								Impeller (Type A)	Roue de turbine	Impulsor	
16	493222	1				1				Impeller (Type B & C)	Roue de turbine	Impulsor	
16	493224		1				1			Impeller	Roue de turbine	Impulsor	
16	493225			1				1		Impeller	Roue de turbine	Impulsor	
16	493870				1				1	Impeller	Roue de turbine	Impulsor	
17	493553	1				1				Volute	Volute	Voluta	
17	493554		1				1			Volute	Volute	Voluta	
17	493555			1				1		Volute	Volute	Voluta	
17	493557				1				1	Volute	Volute	Voluta	
18	144432	1	1	1	1	1	1	1	1	Screw #10 x 3/8 SST	Vis #10 UNC x 3/8 SST	Tornillo #10 UNC x 3/8 SST	
19	116842	1	1	1	1	1	1	1	1	Clamp	Collier de serrage	Abrazadera	
20	246316	1	1	1	1	1	1	1	1	Split Coil Ring, 2.75 O.D. SST	Anneau de levage, 2.75 O.D. SST	Anillo de levante, 2.75 O.D. SST	
21	186220	1	1	1	1	1	1	1	1	Plug 1/4" NPT Brass	Bouchon 1/4 NPT, laiton	Tapón ¼ pulg. NPT de bronce	
25	620385	Accessory									3" Adapter Kit	Ensemble d'adaptateurs 3 po	Juego de adaptador de 3 pulg.
26	206616	1	1	1	1	1	1	1	1	Float switch	Interrupteur à flotteur	Interruptor de flotador	

(NOTE: Float Switch only on automatic units)

* Suggested parts to stock. Important: When ordering parts, specify the model, type, code number and part description.

* Stockage suggéré. Important: Pour commander, indiquer le modèle, le type, le numéro de code et la description des pièces.

* Piezas sugeridas a mantener en inventario. Importante: Cuando pida las piezas de repuesto, especifique el modelo, tipo, número de código y descripción de la pieza.

**When ordering 149413, 246331, 246330, 225051, or 225055, order 225076 and 493541

**En commandant 149413, 246331, 246330, 225051, ou 225055, commandent 225076 et 493541

**Al pedir 149413, 246331, 246330, 225051, o 225055, pide 225076 y 493541

Water Systems
Systèmes d'eau
Sistemas De Agua

Sump and Sewage
Puits et égouts
Sumideros & Desagües

Lawn and Sprinkler
Pompes d'arrosage
Bombas Por Aspersión
Para Riego De Jardines

Electric Motor Driven
Pompes à moteur
électrique
Impulsadas Por Motor
Eléctrico

Engine Driven
Pompes à moteur à
essence
Impulsadas Por Motor

Forme Mount
Montées sur châssis
Para Acople

Hand Pumps
Pompes manuelles
Bomba Manuales

Irrigation and Industrial
Pompes d'irrigation et
pompes industrielles
Bombas Para Irrigación
& Industriales

REPAIR PARTS LIST

LISTE DE PIÈCES DE RECHANGE

LISTA DE PIEZAS DE REPARACIONES

WS SERIES/SÉRIE/SERIE

Submersible Effluent Pumps
 Pompes De Puisard/effluents Submersibles
 Bombas Sumergibles De Desagüe Y Efluentes
 (WS50, WS100)



Water Systems
 Systèmes d'eau
 Sistemas De Agua

Sump and Sewage
 Puisards et égouts
 Sumideros & Desagües

Lawn and Sprinkler
 Pompes d'arrosage
 pour pelouse et jardin
 Bombas Por Aspersión
 Para Riego De Jardines

Electric Motor Driven
 Pompes à moteur
 électrique
 Impulsadas Por Motor
 Eléctrico

Engine Driven
 Pompes à moteur à
 essence
 Impulsadas Por Motor

Frame Mount
 Montées sur châssis
 Para Acople

Hand Pumps
 Pompes manuelles
 Bombas Manuales

Irrigation and Industrial
 Pompes d'irrigation et
 pompes industrielles
 Bombas Para Irrigación
 & Industriales

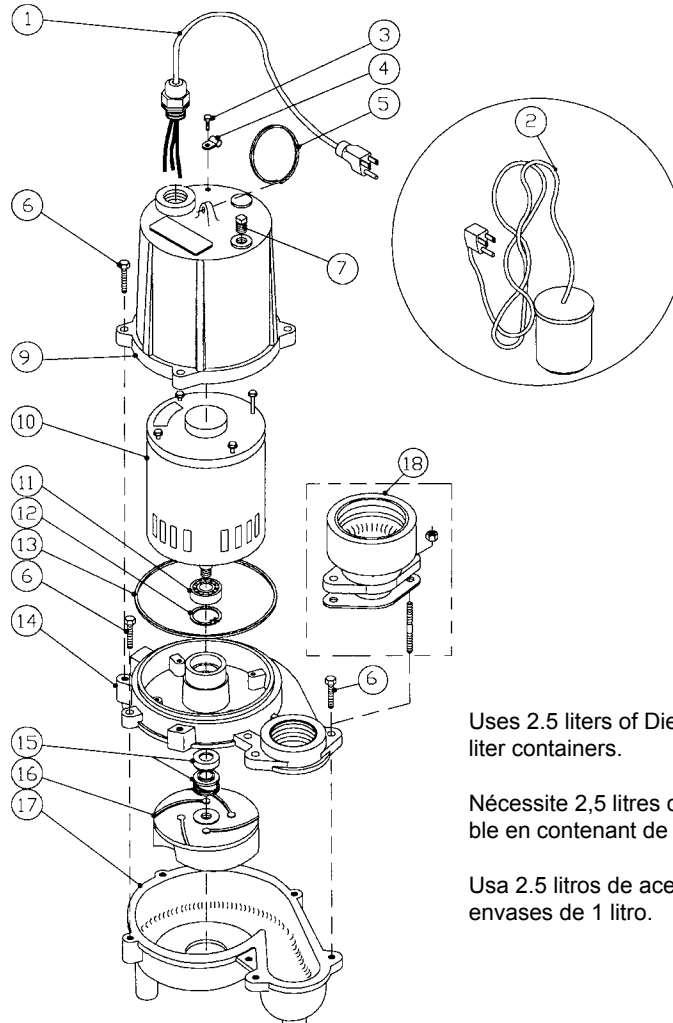

Uses 2.5 liters of Dielectric Oil. Available in 1 liter containers.

Nécessite 2,5 litres d'huile diélectrique disponible en contenant de 1 litre.

Usa 2.5 litros de aceite Dielotric. Disponible en envases de 1 litro.

MODEL KEY / MODÈLE DE RÉFÉRENCE / CLAVE DEL MODELO

When ordering parts, have your pump model number ready for Service Personnel.
 Au moment de commander des pièces au service à la clientèle, ayez en main le numéro du modèle de votre pompe.
 Cuando pida los repuestos, tenga a la mano el número de modelo de su bomba para el personal de servicio.

HP / CV 50 = 1/2 100 = 1 102 = 1	VOLTAGE / VOLTS / VOLTAJE 1 = 115 2 = 208/230 4 = 460 5 = 575	WS 50 H AM -1 2 -20 — Length of cord / Longueur du cordon / Longitud del cable
PHASE / FASES 1 = Single Phase / Monophase / Monofásico 3 = Three Phase / Triphase / Trifásico		— Voltage / Volts / Voltaje — Phase / Fases (AM) Automatic / Automatique / Automática (M) Manual / Manuel — High Head / Hauteur élevée / Alta Presión — HP / CV
Series / Série / Serie		

Ref.	Code #	a	b	c	d	e	f	g	h	i	j	Description	Description	Descripción
1*	225076	1										Single Phase Cords	Cordons monophasés	Cables monofásicos
	225108	1			1						1	115V, 20 ft. (SJOW-A 14/3)	115V, 20 pi (SJOW-A 14/3)	115V, 20 pies (SJOW-A 14/3)
	225064	1	1									115V, 30 ft. (SJOW-A 14/3)	115V, 30 pi (SJOW-A 14/3)	115V, 30 pies (SJOW-A 14/3)
	225107	1	1								1	230V, 20 ft. (SJOW-A 16/3)	230V, 20 pi (SJOW-A 16/3)	230V, 20 pies (SJOW-A 16/3)
	225107	1	1									230V, 30 ft. (SJOW-A 16/3)	230V, 30 pi (SJOW-A 16/3)	230V, 30 pies (SJOW-A 16/3)
	225118							1				230V, 20 ft. (SJOW-A 14/3)	230V, 20 pi (SJOW-A 14/3)	230V, 20 pies (SJOW-A 14/3)
	225119			1		1	1					230V, 30 ft. (SJOW-A 14/3)	230V, 30 pi (SJOW-A 14/3)	230V, 30 pies (SJOW-A 14/3)

200498R6 0506

COLUMN / COLONNE / COLUMNA MODELS / MODÈLES / MODELOS TYPE/TIPO

a	WS50HM, WS50HAM, WS50HM-12, WS50HAM-12	A
b	WS100HM-12, WS100HAM-12, WS100HM-32, WS100HM-34, WS100HM-35	A
c	WS50M-12, WS50AM-12	B
d	WS50HM, WS50HAM	B
e	WS50HM-12, WS50HAM-12	B
f	WS100HM-12, WS100HAM-12	B
g	WS100HM-12-20, WS100HAM-12-20	B
h	WS100HM-32, WS100HM-34	B
i	WS50M-12-20, WS50AM-12-20	B
j	WS50M, WS50AM	B

Ref.	Code #	a	b	c	d	e	f	g	h	i	j	Description	Description	Descripción	
1*	225116		1								1	3 Phase Cords (without plug) 30 ft., All voltages (SOW-A 16/4)	Cordons triphasés (sans prise) 30 pi - Tous voltages (SOW-A 16/4)	Cables trifásicos (sin enchufe) 30 pies, todos los voltajes (SOW-A 16/4)	
	225109											20 ft., All voltages (SOW-A 16/4)	20 pi - Tous voltages (SOW-A 16/4)	20 pies, todos los voltajes (SOW-A 16/4)	
2	639606	1										Float Switch (AM models only) 115V, 20 ft.	Interrupteur à flotteur (modèles automatiques seulement) 115V, 20 pi	Interruptor de Flotador (Modelos AM solamente) 115V, 20 pies	
	639607	1			1						1	115V, 30 ft.	115V, 30 pi	115V, 30 pies	
	639603										1	230V, 20 ft.	230V, 20 pi	230V, 20 pies	
	639609		1						1			230V, 15A, 20 ft.	230V, 15A, 20 pi	230V, 15A, 20 pies	
	639604			1		1						230V, 30 ft.	230V, 30 pi	230V, 30 pies	
	639610		1						1			230V, 15A, 30 ft.	230V, 15A, 30 pi	230V, 15A, 30 pies	
3	144432	1	1	1	1	1	1	1	1	1	1	Screw #8 - 32 UNC x 3/8"	Vis #8 - 32 UNC x 3/8	Tornillo #8 - 32 UNC x 3/8 pulg.	
4	116842	1	1	1	1	1	1	1	1	1	1	Clamp	Collier de serrage	Abrazadera	
5	246316	1	1	1	1	1	1	1	1	1	1	Split Coil Ring, 2.75 O.D. SST	Anneau de levage, 2.75 O.D. SST	Anillo de bobina separada, 2.75 O.D. SST	
6	225820	10	10	10	10	10	10	10	10	10	10	Bolt 5/16" UNC x 1-1/4" SST	Boulon 5/16 UNC x 1-1/4 SST	Perno 5/16 pulg. UNC x 1-1/4 pulg. SST	
7	186220	1	1	1	1	1	1	1	1	1	1	Plug 1/4" NPT Brass	Bouchon 1/4 NPT, laiton	Tapón 1/4 pulg. NPT de bronce	
8	620581	2.5	2.5	2.5	2.5	2.5	2.5	2.5	2.5	2.5	2.5	Insulating Oil	Huile isolante	Aceite aislante	
9	493543	1	1	1	1	1	1	1	1	1	1	Housing	Boîtier	Cuerpo de la bomba	
10	238251	1										Motor 1/2HP, 115/208-230V, 1PH.	Moteur 1/2 CV, 115/208-230V, 1PH.	Motor 1/2 HP, 115/208-230V, 1 Fases	
	238255		1									Motor 1HP, 3PH., 208-230/460V	Moteur 1 CV, 3PH., 208-230/460V	Motor 1 HP, 3 F., 208-230/460V	
	238257		1									Motor 1HP, 3PH., 575V	Moteur 1 CV, 3PH., 575V	Motor 1 HP, 3 F., 575V	
	238252		1									Motor 1HP, 1PH., 208-230V	Moteur 1 CV, 1PH., 208-230V	Motor 1 HP, 1 F., 208-230V	
	238258											Motor 1HP, 3PH., 575V, 1750RPM	Moteur 1 CV, 3PH., 575V, 1750RPM	Motor 1 HP, 3 F., 575V, 1750 RPM	
	238254											Motor 1HP, 1PH., 115/208-230V	Moteur 1 CV, 1PH., 115/208-230V	Motor 1 HP, 1 F., 115/208-230V	
	238256											Motor 1HP, 3PH., 208-230/460V	Moteur 1 CV, 208-230/460V	Motor 1 HP, 3 F., 208-230/460V	
	238262				1							1	Motor 1/2HP, 1PH., 115V	Moteur 1/2 CV, 1PH., 115V	Motor 1/2 HP, 1 F., 115V
	238263			1		1							Motor 1/2HP, 1PH., 208-230V	Moteur 1/2 CV, 1PH., 208-230V	Motor 1/2 HP, 1 F., 208-230V
	238266												Motor 1HP, 1PH., 208-230V	Moteur 1 CV, 1PH., 208-230V	Motor 1 HP, 1 F., 208-230V
238264							1	1				Motor 1HP, 1PH., 208-230V	Moteur 1 CV, 1PH., 208-230V	Motor 1 HP, 1 F., 208-230V	
238265											1	Motor 1HP, 3PH., 208-230/460V	Moteur 1 CV, 3PH., 208-230/460V	Motor 1 HP, 3 F., 208-230/460V	
238267												Motor 1HP, 3PH., 208-230/460V	Moteur 1 CV, 3PH., 208-230/460V	Motor 1 HP, 3 F., 208-230/460V	
11*	110110	2	2	2	2	2	2	2	2	2	2	Bearing (included with #10)	Coussinet (inclus avec #10)	Rodamiento (incluido con #10)	
12	137911	1	1	1	1	1	1	1	1	1	1	Retaining Ring	Anneau de retenue	Anillo de retención	
13*	198994	1	1	1	1	1	1	1	1	1	1	O-Ring, Square	Joint torique, carré	Anillo en "O", Cuadrado	
14	493552	1	1	1	1	1	1	1	1	1	1	Adapter	Adaptateur	Adaptador	
	493563											Adapter	Adaptateur	Adaptador	
15*	240160	1	1	1	1	1	1	1	1	1	1	Mechanical Seal, 5/8" I.D.	Joint mécanique, 5/8, D.E.	Sello mecánico, 5/8 pulg. I.D.	
16*	493227	1			1	1						Impeller	Roue de turbine	Propulsor	
	493229		1					1	1			Impeller	Roue de turbine	Propulsor	
	493230											Impeller	Roue de turbine	Propulsor	
	493575			1							1	1	Impeller	Roue de turbine	Propulsor
17	493553	1	1	1	1	1	1	1	1	1	1	Casing	Boîtier	Cuerpo de la bomba	
	493557											Casing	Boîtier	Cuerpo de la bomba	
18	620385	Accessory										Adapter Kit 3"	Ensemble d'adaptateurs 3 po	Juego de adaptador de 3 pulg.	

* Suggested parts to stock. Important: When ordering parts, specify the model, type, code number and part description. **Cord Assemblies:** All pump models are available with 20 ft. or 30 ft. cords and Piggy Back float switches. Choose the appropriate length for your model.

* Stockage suggéré. Important : Pour commander, indiquer le modèle, le type, le numéro de code et la description des pièces. **Assemblages de cordons :** Tous les modèles de pompes sont disponibles avec des cordons de 20 pi ou de 30 pi, et des interrupteurs à flotteur munis d'une fiche-prise. Choisissez la longueur qui convient à votre modèle.

* Piezas sugeridas a mantener en inventario. Importante: Cuando pida las piezas de repuesto, especifique el modelo, tipo, número de código y descripción de la pieza. **Conjunto de cables:** Todas las bombas están disponibles con cables de 20 o 30 pies de largo, y con interruptores de flotador a cuestas. Elija el tamaño adecuado para su modelo.

Water Systems
Systèmes d'eau
Sistemas De Agua

Sump and Sewage
Puits et égouts
Sumideros & Desagües

Lawn and Sprinkler
Pompes à arrosage
pour pelouse et jardin
Bombas Por Aspersión
Para Riego De Jardines

Electric Motor Driven
Pompes à moteur
électrique
Impulsadas Por Motor
Eléctrico

Engine Driven
Pompes à moteur à
essence
Impulsadas Por Motor

Forme Mount
Montées sur châssis
Para Acople

Hand Pumps
Pompes manuelles
Bomba Manuales

Irrigation and Industrial
Pompes d'irrigation et
pompes industrielles
Bombas Para Irrigación
& Industriales